



AirPro EFX™

Automatic Air Spray Gun Designed for Precision Finishing



PROVEN QUALITY. LEADING TECHNOLOGY.

Precision Finishing



Setting the Performance Benchmark

The AirPro EFX is a complete line of air spray automatic guns with optimized performance for the most precise spray finishing. All aspects of the AirPro EFX are designed to meet the demands of small component precision finishing including:

- Aircaps and nozzles deliver superior, precision spray performance
- Precision fluid adjustment with a micrometer-telescoping knob
- High wear components designed for abrasive materials
- Excellent fluid flow rate stability and repeatability
- Compact and lightweight gun

Innovative Engineering and Design

Infused with the latest technology and performance features, the AirPro EFX gun offers countless innovations for the fine finish market.

- 5 spray technologies including the exclusive HiTEch
- 6 nozzle sizes for flow rates as low as 10 cc per minute, up to 350 cc per minute
- 3 fluid adjustment knobs for greater flow rate precision
- 2 mounting styles for manufacturing line flexibility

Breakthrough Technology

Apply Superior Finishes

Each AirPro EFX gun is analyzed for spray pattern excellence so you get precise coverage every time you spray.

Laser light imaging technology verifies spraying benchmarks are met or exceeded for each AirPro EFX gun – guaranteeing the following criteria:

- High quality spray pattern shape
- Enhanced atomization for outstanding finish quality
- Even material distribution through the spray pattern for optimum coverage

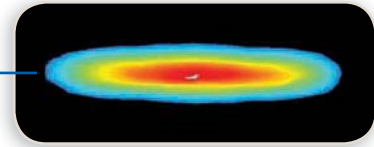

Actual spray pattern produced using laser light sheet imaging technology

Advanced Air cap Technologies

HiTEch

A high transfer efficiency gun with excellent atomization.

Air caps and nozzles are designed to deliver superior finish quality while reducing overspray.



Air Brush

Delivers a round spray pattern for precise, small surface area spraying.

The ability to control pattern size decreases material usage.



Versatile Product Line

Offered in five air spray technologies, including air brush, Graco's AirPro EFX automatic gun has the versatility and flexibility to accommodate a variety of spraying needs.



	HiTEch	LVMP	HVLP	CONVENTIONAL
FINISH QUALITY	Best	Better	Good	Best
TRANSFER EFFICIENCY	High	Medium	Medium	Low
FLUID FLOW	Medium	Medium	Low	High
AIR FLOW	High	Low	High	Low

Engineered for Accuracy

Light, Compact and Perfect for Robotic Applications!

The AirPro EFX air spray automatic guns are among the lightest and most compact guns in their class. With no internal air shutoff mechanism, the AirPro EFX delivers increased reliability and precision fluid flow. The modest size and weight of this gun make it an excellent choice for fixed, reciprocating and robotic applications.

Features

- 1 Air caps**
 - Available in five air spray technologies, including HiTEch and air brush
 - Indexing air cap provides fast, accurate positioning in the vertical or horizontal position
- 2 Nozzle and Needle**
 - Optimized for maximum flow rate adjustability
 - Available in tungsten carbide for increased life with abrasive and metallic coatings
 - Delivers excellent flow rate stability and repeatability
- 3 Needle Packing**
 - Design and material construction is durable for long life with abrasive materials, including UV coatings
- 4 Three Fluid Adjustment Knob Styles**
- 5 Air Inlet**
 - Separate inlets for atomizing, fan and trigger air provide increased control
 - Quick disconnect air fittings decrease time needed for repairs
- 6 Two Mounting Styles**

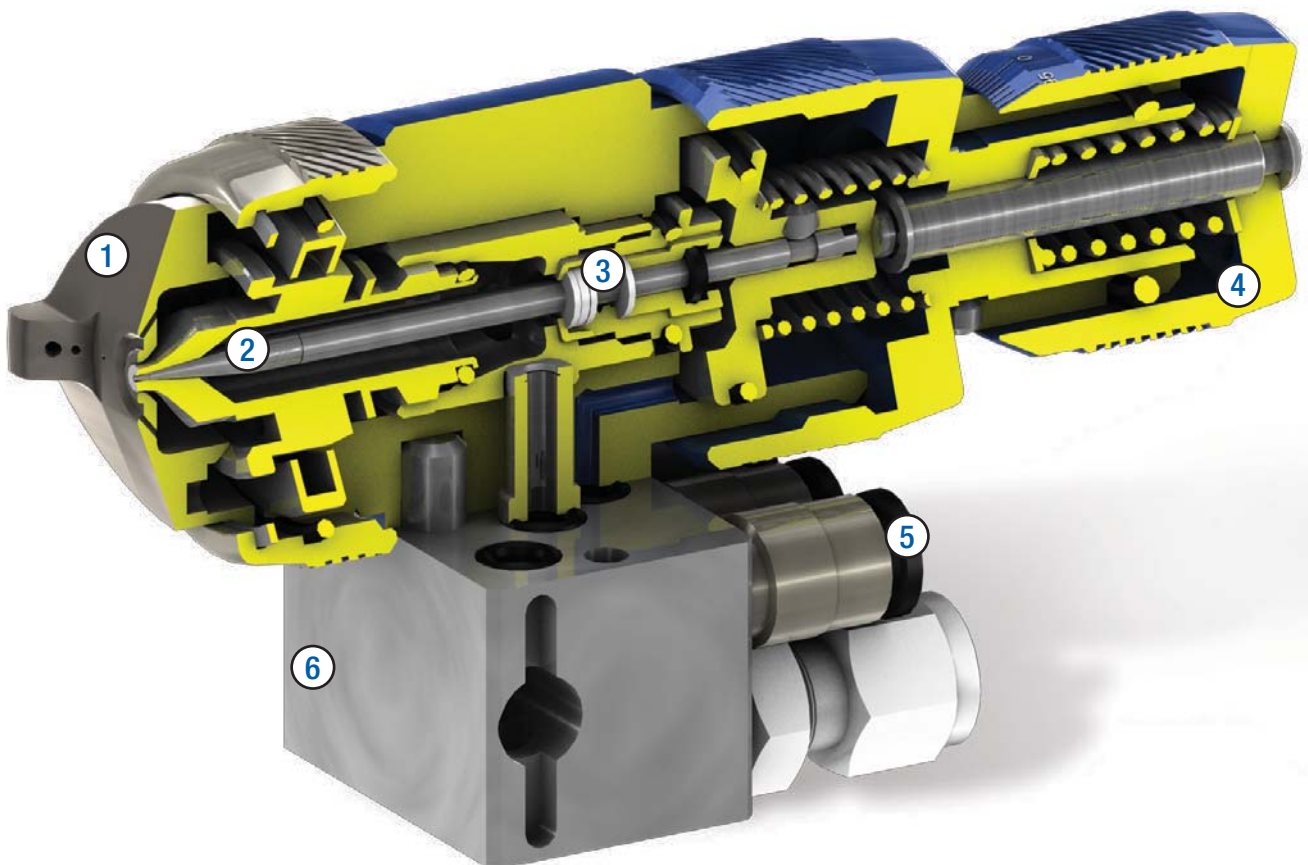

Mounting and Fluid Adjustment Options

Fluid Adjustment Knobs

Ultra precision knob



Micrometer telescoping knob for precision fluid adjustment with numerical indexing for retainable adjustment settings

Indexing knob



Fluid adjustment in fine flow increments

Lock ring and cap



Simple thread adjustment with locking ring

Flexible Gun Mounting

Manifold Style

- Durable stainless steel fluid passages
- Recirculation up to the nozzle for no dead spots
- Quick removal of the gun from the manifold for easy repair
- Manifold guarantees gun positioning even after gun repairs
- Mounting rod included for ease of installation



Direct Connect Style

- Hose fittings connect directly to gun
- Quick disconnect air fittings
- HiTEch gun models have stainless steel fluid fittings
- Top attachment slot for consistent mounting



design

Ordering Information

Ordering Information

1. Choose Manifold or Direct Connect style gun
2. Select Spray Type (HiTEch, LVMP, HVLP, Conventional or Air Brush)
3. Select material viscosity
4. Select average flow rate

Manifold Style Guns

Part Number	Spray Type	Nozzle Size	Material Viscosity*	Flow	Needle Tip/ Nozzle Material	Fluid Adjustment Knob	Needle/Nozzle Kit Part No.	Air Cap with Pin Part No.
24B866	HiTEch	0.7 mm (0.028 in)	light	10 - 100 cc/min (0.3 - 3.4 oz/min)	SST	Ultra Precision	24D303	24D703
24B867	HiTEch	1.0 mm (0.039 in)	light-medium	20 - 200 cc/min (0.7 - 6.8 oz/min)	Carbide	Ultra Precision	24C221	24D703
24B868	HiTEch	1.5 mm (0.059 in)	medium	45 - 450 cc/min (1.5 - 15.2 oz/min)	Carbide	Ultra Precision	24C201	24D704
24B869	LVMP	0.5 mm (0.020 in)	light	5 - 50 cc/min (0.2 - 1.7 oz/min)	SST	Ultra Precision	24D277	24C184
24B870	LVMP	0.7 mm (0.028 in)	light	10 - 100 cc/min (0.3 - 3.4 oz/min)	SST	Ultra Precision	24D278	24C184
24B871	LVMP	0.9 mm (0.035 in)	light-medium	15 - 150 cc/min (0.5 - 5.1 oz/min)	SST	Ultra Precision	24D279	24C184
24B872	LVMP	1.1 mm (0.043 in)	light-medium	25 - 250 cc/min (0.8 - 8.5 oz/min)	SST	Ultra Precision	24D280	24C184
24B873	LVMP	1.3 mm (0.051 in)	medium	35 - 350 cc/min (1.2 - 11.8 oz/min)	SST	Ultra Precision	24D281	24C184
24B874	LVMP	1.5 mm (0.059 in)	medium	45 - 450 cc/min (1.5 - 15.2 oz/min)	Carbide	Ultra Precision	24D284	24C184
24B862	HVLP	0.5 mm (0.020 in)	light	5 - 50 cc/min (0.2 - 1.7 oz/min)	SST	Indexing	24D302	24C183
24B863	HVLP	0.7 mm (0.028 in)	light	10 - 100 cc/min (0.3 - 3.4 oz/min)	SST	Indexing	24D303	24C183
24B864	HVLP	1.1 mm (0.043 in)	light-medium	25 - 250 cc/min (0.8 - 8.5 oz/min)	SST	Indexing	24D305	24C183
24B865	HVLP	1.3 mm (0.051 in)	medium	35 - 350 cc/min (1.2 - 11.8 oz/min)	SST	Indexing	24D306	24C183
24B857	Conventional	0.7 mm (0.028 in)	light	10 - 100 cc/min (0.3 - 3.4 oz/min)	SST	Indexing	24C197	24C182
24B858	Conventional	0.9 mm (0.035 in)	light-medium	15 - 150 cc/min (0.5 - 5.1 oz/min)	SST	Indexing	24C198	24C182
24B859	Conventional	1.1 mm (0.043 in)	light-medium	25 - 250 cc/min (0.8 - 8.5 oz/min)	SST	Indexing	24C199	24C182
24B860	Conventional	1.3 mm (0.051 in)	medium	35 - 350 cc/min (1.2 - 11.8 oz/min)	SST	Indexing	24C200	24C182
24B861	Conventional	1.5 mm (0.059 in)	medium	45 - 450 cc/min (1.5 - 15.2 oz/min)	Carbide	Indexing	24C201	24C182
24B875	Air Brush	0.7 mm (0.028 in)	light	10 - 100 cc/min (0.3 - 3.4 oz/min)	SST	Indexing	24C197	24D705

Direct Connect Style Guns

Part Number	Spray Type	Nozzle Size	Material Viscosity*	Flow	Needle Tip/ Nozzle Material	Fluid Adjustment Knob	Needle/Nozzle Kit Part No.	Air Cap with Pin Part No.
24B884	HiTEch	0.7 mm (0.028 in)	light	10 - 100 cc/min (0.3 - 3.4 oz/min)	SST	Ultra Precision	24D303	24D703
24B885	HiTEch	1.0 mm (0.039 in)	light-medium	20 - 200 cc/min (0.7 - 6.8 oz/min)	Carbide	Ultra Precision	24C221	24D703
24B886	HiTEch	1.5 mm (0.059 in)	medium	45 - 450 cc/min (1.5 - 15.2 oz/min)	Carbide	Ultra Precision	24C201	24D704
24B887	LVMP	0.5 mm (0.020 in)	light	5 - 50 cc/min (0.2 - 1.7 oz/min)	SST	Indexing	24D277	24C184
24B888	LVMP	0.7 mm (0.028 in)	light	10 - 100 cc/min (0.3 - 3.4 oz/min)	SST	Indexing	24D278	24C184
24B889	LVMP	0.9 mm (0.035 in)	light-medium	15 - 150 cc/min (0.5 - 5.1 oz/min)	SST	Indexing	24D279	24C184
24B890	LVMP	1.1 mm (0.043 in)	light-medium	25 - 250 cc/min (0.8 - 8.5 oz/min)	SST	Indexing	24D280	24C184
24B891	LVMP	1.3 mm (0.051 in)	medium	35 - 350 cc/min (1.2 - 11.8 oz/min)	SST	Indexing	24D281	24C184
24B881	HVLP	0.7 mm (0.028 in)	light	10 - 100 cc/min (0.3 - 3.4 oz/min)	SST	Indexing	24D303	24C183
24B882	HVLP	1.1 mm (0.043 in)	light-medium	25 - 250 cc/min (0.8 - 8.5 oz/min)	SST	Indexing	24D305	24C183
24B883	HVLP	1.3 mm (0.051 in)	medium	35 - 350 cc/min (1.2 - 11.8 oz/min)	SST	Indexing	24D306	24C183
24B877	Conventional	0.7 mm (0.028 in)	light	10 - 100 cc/min (0.3 - 3.4 oz/min)	SST	Lock Ring	24C197	24C182
24B878	Conventional	0.9 mm (0.035 in)	light-medium	15 - 150 cc/min (0.5 - 5.1 oz/min)	SST	Lock Ring	24C198	24C182
24B879	Conventional	1.1 mm (0.043 in)	light-medium	25 - 250 cc/min (0.8 - 8.5 oz/min)	SST	Lock Ring	24C199	24C182
24B880	Conventional	1.3 mm (0.051 in)	medium	35 - 350 cc/min (1.2 - 11.8 oz/min)	SST	Lock Ring	24C200	24C182
24B892	Air Brush	0.7 mm (0.028 in)	light	10 - 100 cc/min (0.3 - 3.4 oz/min)	SST	Indexing	24C197	24D705

Technical Specifications

Technical Data

Maximum working fluid pressure	7 bar (100 psi, 0.7 MPa)
Maximum working air pressure	7 bar (100 psi, 0.7 MPa)
Maximum working fluid temperature	49°C (120°F)
Minimum air cylinder actuation pressure3.4 bar (50 psi, 0.34 MPa)

Weight

Manifold style guns	575 g (1.3 lb)
Direct Connect style guns	275 g (0.6 lb)

Wetted Parts

Manifold style guns	Nylon, PTFE, Stainless Steel, Ultra High Molecular Weight Polyethylene, Tungsten Carbide
Direct Connect style guns	Anodized Aluminum, Stainless Steel, Ultra High Molecular Weight Polyethylene, Tungsten Carbide, Nylon

Triggering Speed

These values apply to a new gun with a 12 ft (3.6 m), 1/4 in (6.3 mm) OD cylinder air line and a 1.1 m (0.043 in) nozzle.

Values will vary slightly with use and with variations in equipment.

Cylinder Air Pressure	Fluid Pressure	Air Pressure	MSEC to Fully Open	MSEC to Fully Close
3.5 bar (50 psi, 0.35 kPa)	3.5 bar (50 psi, 0.35 kPa)	7 bar (100 psi, 0.7 kPa)	48	84

Accessories

- 24C216 Fittings Kit, 1/4 inch - Includes 3 air fittings and 2 fluid fittings
- 24D143 Robot Adapter Kit Fanuc Paint Mate 200 - Compatible with and without manifold
- 24D008 Inlet Air Needle Valve - Includes needle valve and 6 mm tube fitting
- 24C214 HVLP Pressure Verification Kit
For use in checking air cap atomizing and fan pattern air pressure at various supply air pressures. Not to be used for actual spraying.

Fluid Adjustment Knobs

- 24D065 Ultra-Precision Knob
Micrometer telescoping knob which is indexed for precision adjustment
- 24C204 Indexing Knob
Fluid adjustment in fine flow increments
- 24C203 Lock Ring and Cap
Simple thread adjustment with locking ring

Needle Assembly Identification

Part Number	Needle Assembly Size	# of Grooves	Material
24C190	0.5 mm (0.020 in)	1	SST
24C191	0.7 mm (0.028 in)	2	SST
24C192	0.9 mm (0.035 in)	3	SST
24C220	1.0 mm (0.039 in)	0	Carbide
24C193	1.1 mm (0.043 in)	4	SST
24C194	1.3 mm (0.051 in)	5	SST
24C195	1.5 mm (0.059 in)	0	Carbide





ABOUT GRACO

Founded in 1926, Graco is a world leader in fluid handling systems and components. Graco products move, measure, control, dispense and apply a wide range of fluids and viscous materials used in vehicle lubrication, commercial and industrial settings.

The company's success is based on its unwavering commitment to technical excellence, world-class manufacturing and unparalleled customer service. Working closely with qualified distributors, Graco offers systems, products and technology that set the quality standard in a wide range of fluid handling solutions. Graco provides equipment for spray finishing, protective coating, paint circulation, lubrication, and dispensing sealants and adhesives, along with power application equipment for the contractor industry. Graco's ongoing investment in fluid management and control will continue to provide innovative solutions to a diverse global market.

GRACO LOCATIONS

CONTACT

MAILING ADDRESS

P.O. Box 1441
Minneapolis, MN 55440-1441
Tel: 612.623.6000
Fax: 612.623.6777

AMERICAS

MINNESOTA

Worldwide Headquarters
Graco Inc.
88-11th Avenue N.E.
Minneapolis, MN 55413

EUROPE

BELGIUM

European Headquarters
Graco N.V.
Industrieterrein - Oude Bunders
Slakweidestraat 31
3630 Maasmechelen,
Belgium
Tel: 32.89.770.700
Fax: 32.89.770.777

ASIA PACIFIC

JAPAN

Graco K.K.
1-27-12 Hayabuchi
Tsuzuki-ku
Yokohama City, Japan 2240025
Tel: 81.45.593.7300
Fax: 81.45.593.7301

ASIA PACIFIC

CHINA

Graco Hong Kong Ltd.
Representative Office
Room 118 1st Floor
No.2 Xin Yuan Building
No.509 Cao Bao Road
Shanghai, P.R. China 200233
Tel: 86.21.649.50088
Fax: 86.21.649.50077

ASIA PACIFIC

KOREA

Graco Korea Inc.
Choheung Bank Building
4th Floor #1599
Gwanyang-Dong, Dongan-Ku,
Anyang-Si, Gyunggi-Do,
Korea 431-060
Tel: 82(Korea).31.476.9400
Fax: 82(Korea).31.476.9801

All written and visual data contained in this document are based on the latest product information available at the time of publication.
Graco reserves the right to make changes at any time without notice.

Graco is certified ISO 9001.

Europe
+32 89 770 700
FAX +32 89 770 777
WWW.GRACO.COM